

1 Foreword

1.1 General Instructions

This guide will help you to use the RUD bucket suspension safely, properly and profitably. When you follow the instructions in this guide, you will

- Increase the reliability and service life of the RUD bucket suspension and the system
- Avoid dangers
- Reduce repairs and down times

This guide must

- **Be available at all times at the place of use**
- **Be read and followed by everyone who works on the RUD bucket suspension.**

The RUD bucket suspension has been manufactured according to the state-of-the-art and in compliance with the recognized safety rules. However, improper handling or use for other than intended purpose may endanger the life and limb of the user or third parties and/or damage the conveyor system or other tangible assets.

Spare parts must fulfill the technical requirements specified by RUD Ketten. This is guaranteed in the case of original spare parts as they are subjected to continuous quality control by a quality management system certified under ISO 9001. Third party spare parts may, under certain circumstances, change the specified design characteristics of the system and lead to serious defects which, in such a case, would not be the responsibility of RUD Ketten.

Use a suitably equipped workshop for performing maintenance work. Only the manufacturer can guarantee to carry out a professional overhaul or repair.

This guide has been drawn up with the greatest possible care. However, if you would like further information, please contact:

RUD Ketten
Rieger & Dietz GmbH u. Co. KG
Friedensinsel
73432 Aalen/Germany
Telephone +49 7361 504-0
Fax +49 7361 504-1523
rudketten@rud.com
www.rud.com

© 2007.

This guide is copyright protected. RUD Ketten reserves the right to make changes.



1.2 Use for the Intended Purpose

- The RUD bucket suspension is a means of attaching buckets to chains.
- In stationary operation, the permitted power transfer through the bucket suspension when conveying a specific material at a specific speed and with an appropriate distance between axes is specified in the order placed with RUD and in the confirmation of order by RUD. Any other use or use going beyond the intended use – for example higher conveying capacities or speeds, conveying other materials, or use under unapproved operating conditions – shall be regarded as use for other than the intended purpose.
- Usage for the intended purpose also includes complying with this fitting and operating guide, and complying with the inspection and maintenance specifications.

The manufacturer shall not be liable for damage resulting from usage for other than the intended purpose. The user shall bear the risk alone.

2 Safety Instructions

2.1 Explanation of Symbols and Notices

 <p>Warning!</p>	<p>Danger to life and limb, or substantial material damage can occur if the appropriate safety instructions are not followed.</p>
 <p>Attention!</p>	<p>Undesirable consequences or working conditions can arise if the appropriate safety instructions are not followed.</p>

2.2 General

 <p>Warning!</p>	<p>Follow the safety instructions. Otherwise there is danger to the life and limb of the user and third parties, and of damage to the machine and other tangible assets.</p>
---	---

- Mounting, dismounting, repairs, overhauls, and wear measurement may only be performed by competent persons who are familiar with the operating manuals and trained people.
- Inform the operating personnel and appoint supervisors before starting maintenance work.
- Secure machines and equipment against being started unintentionally.
- Switch off the main control systems, remove keys, and attach warning notices.
- Before mounting/dismounting work, secure the chain strand against movement. When mounting/dismounting chain equipment, a one-sided load can set the chain in motion and cause injuries which may prove to be fatal.
- Protect the working area against falling materials and components.
- When mounting and replacing individual parts or larger modules, attach and secure them carefully to the lifting equipment so that they cannot become a source of danger. Only use suitable and technically faultless lifting equipment and load hitching tackle.
- Do not stand or walk under suspended loads.
- As a rule, all components must be mounted and dismantled in an electrically dead state, unless otherwise stated. Risk of crushing!
- All parts of the plant must have cooled down to the extent that they can be touched without causing burns.

- Appoint only operating personnel with valid certificates of entitlement to hitch loads and instruct crane drivers. The spotter must remain in view of the operator or be in voice contact with him.
- The platforms provided and climbing aids complying with safety regulations must be used for assembly work above head height. Do not use machine parts as climbing aids. Wear protection against falling when performing maintenance work at great heights.
- Operating and process materials must be disposed of safely and in a way that does not harm the environment.
- As a matter of principle, no welding work is permitted to be done on round steel chains, chain couplings or case-hardened module components. The chain must not be used as a ground connection to the steel structure for electric welding.
- Welding, burning and grinding work may only be performed on the plant when this has been expressly authorized. Before starting welding, burning or grinding work, clean the plant and its surroundings of dust and combustible materials, and ensure adequate ventilation. There could, for example, be a risk of fire or explosion.
- Ensure that screw connections are tightened with the defined torque. Always check these connections with a torque wrench.
- Persons are not allowed to ride on the conveyor.
- For safety reasons, it is forbidden to make any modifications or alterations to the components without the manufacturer's authorization.
- All methods of working which are of questionable safety are forbidden.
- In addition to the operating instructions, comply with and implement the generally applicable, legal and other binding accident prevention and environmental protection regulations. For example, the handling of hazardous substances and the provision and wearing of personal protective clothing and equipment.

2.3 Care and Maintenance

- Wherever necessary, cordon off the maintenance area, allowing a wide safety margin.
- Before starting maintenance work, cordon off the working area of the machine/equipment to prevent the access of unauthorized persons. Attach or put up suitable notices advising of the maintenance work.

Any material adhering to or remaining in the buckets can come loose and fall out. Switch off the material feed, and empty the bucket elevator before opening the inspection flaps. Wear a safety helmet while working.

3 Description

- The bucket attachment is attached to the back of the bucket.
- For DIN 15233 and 15234 buckets and special types of buckets (high capacity buckets).
- Variable bucket spacings.
- For bucket elevators with toothed and non-toothed drive wheels.
- For standard bucket elevators and mixed emptying.

Scope of supply:

- 2 Pre-assembled, riveted shackles
- 2 Stud bolts
- 2 DIN 980-8 locking nuts V

The equipment is supplied with the stud bolts and locking nuts pre-assembled.

The main parts (figure 1) are:

- Shackle **81**
- Stud bolt **82**
- Locking nut **83**

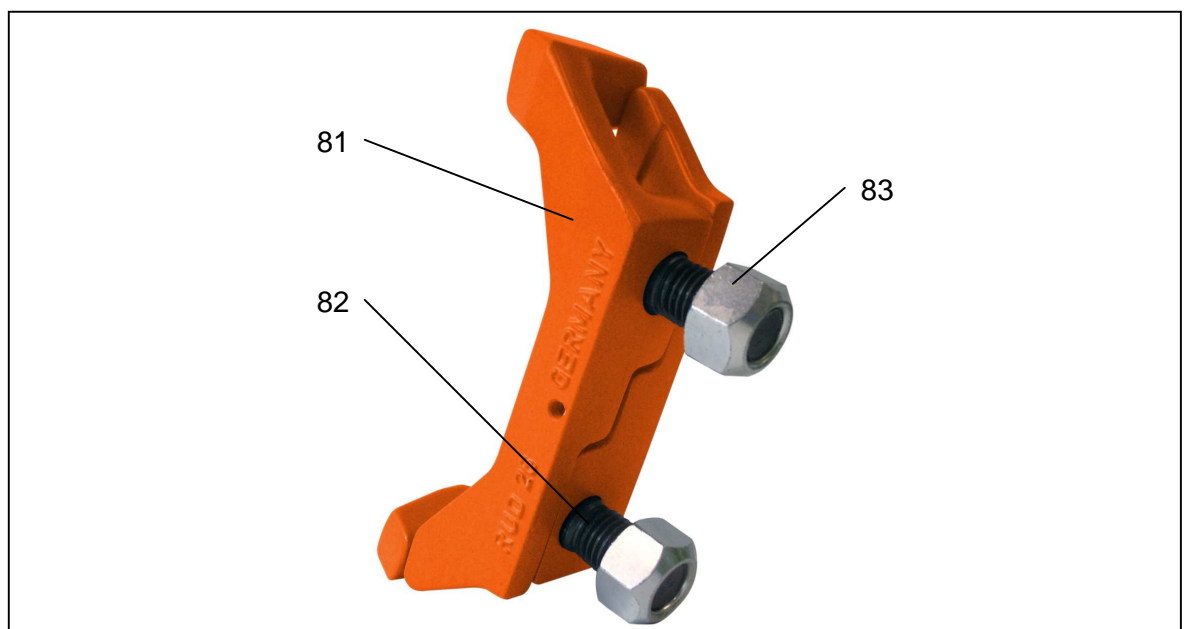

Fig. 1

4 Assembly



Step 1:
Turn the shackles against each other.



Step 2: Hook the **2win** into the chain.

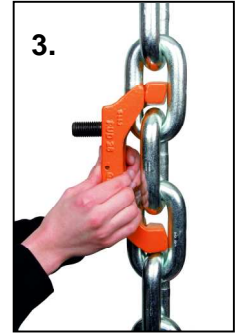

Step 3: Close the **2win**.

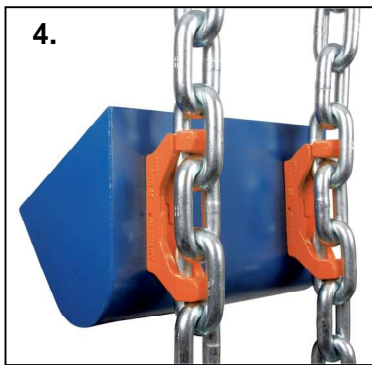

Step 4:
Attach the bucket by screwing two nuts onto the two stud bolts.
The permissible bolt tightening torques are to be found in the table in the last section.

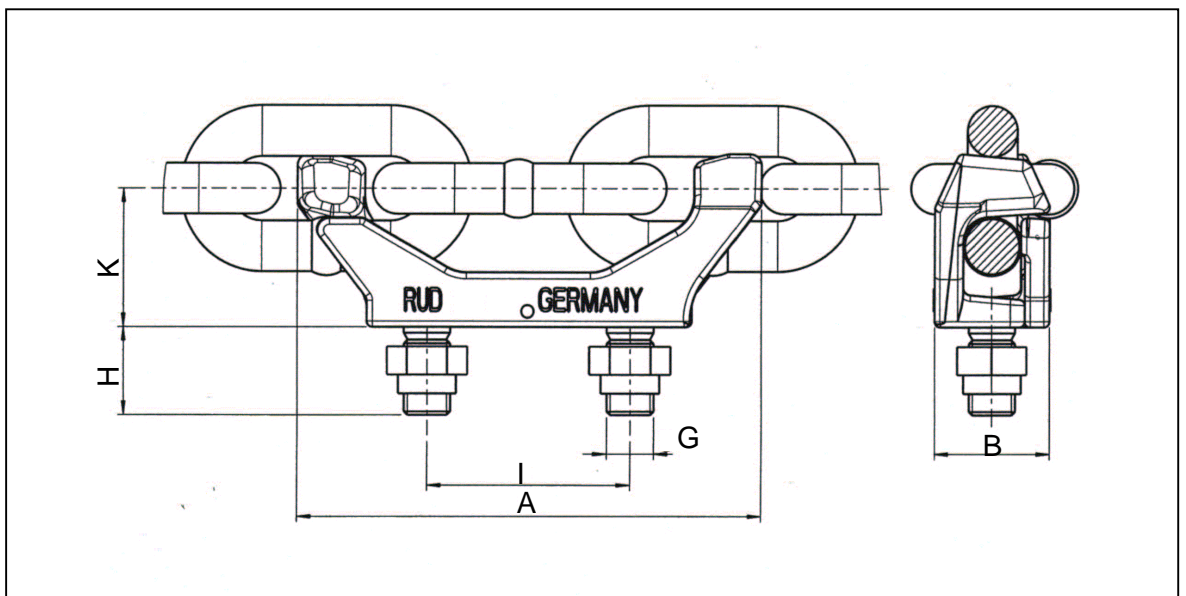
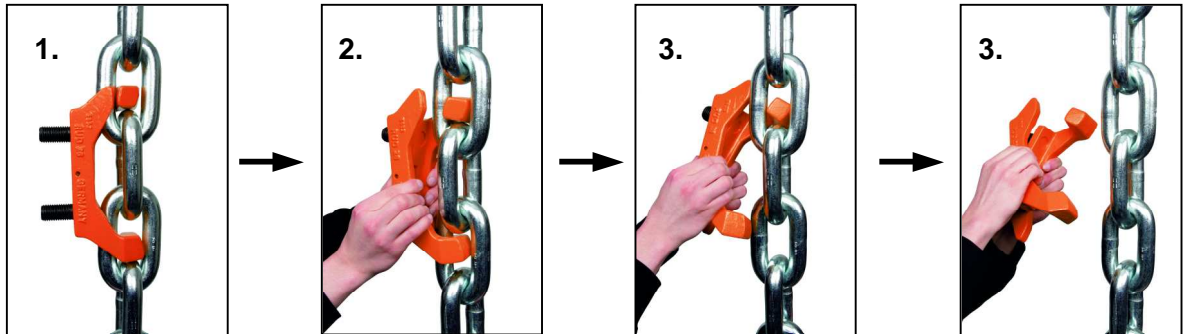

Fig. 2

5 Disassembly



Step 1:
Unscrew the nuts and
remove the bucket.

Step 2:
Turn the
shackles against
each other.

Step 3: Hook the
2win out of the chain.

6 Care and Maintenance

6.1 Lubrication

Under normal circumstances, RUD conveyor chains do not require any lubrication. The chains may only be lubricated with standard engine oil. Grease must not be used. Dirty chains should be cleaned before being lubricated.

6.2 Monitoring

Examine the bucket suspension every six months, or at least annually, for damage, corrosion and wear in unusual places. Pay particular attention to the condition of the screw connections and safety components. Rectify all defects found without delay

7 Wear and Replacement State of Wear

When changing chains, check the attachments for damage, corrosion and wear in unusual places. If such defects are found, change the attachments or, if necessary, consult RUD Ketten.

Attention!

The attachments must always be replaced when damage occurs which directly or indirectly endangers the safety or operation of the plant.

8 Maximum Permissible Bolt Tightening Torques

The factors influencing the tightening torques stated in VDI 2230 must be taken into account when mounting bolted parts. Retighten all nuts after two weeks' operation, and ensure that they are tightly seated.

8.1 Table 1: Maximum Tightening Torques

Thread size	For bolt strength class 8.8 with overall coefficient of friction $\mu_{\text{over}} = 0.14$		2win and SWA threads with overall coeff. of friction $\mu_{\text{over}} = 0.14$		For DIN 555 hex nuts quality class 5	For DIN 934 hex nuts quality class 8	For DIN 980V hex nuts
	Tightening torque (Nm)	Tightening torque (ft-pd)	Tightening torque (Nm)	Tightening torque (ft-pd)	Tightening torque (Nm)	Tightening torque (Nm)	Tightening torque (Nm)
M 6	10	7					
M 8	25	18					
M 10	49	35			30	51	55
M 12	85	62			52	89	95
M 14	135	98			83	140	149
M 16	210	152	149	108	127	213	225
M 20	425	307	293	212	245	420	439
M 22	580	420					
M 24	730	528	506	366	420	725	752
M 27	1100	796					
M 30	1450	1049	1000	723	847	1451	1487
M 33	1900	1347					
M 36	2450	1772	1700	1230	1480	2531	2575

8.2 Table 2: Recommended Values for the Tightening Factor α_A :

Tightening factor α_A	Variation	Tightening method	Setting method	Comments	
1.7 to 2.5	26% to 43%	Torque-controlled tightening with mechanical screwdriver	The screwdriver is set with a tightening torque comprising a nominal tightening torque (for estimated coefficient of friction) plus an allowance.	Low values for: → Large number of checks (tightening torque) → Screwdriver with breaking coupling	Low values for: → Small angles of rotation, i.e. relatively rigid connections. → Relatively soft backing. → Backings which do not tend to scuff. Higher values for: → Large angles of rotation, i.e. relatively flexible connections. → Very hard backing coupled with rough surface. → Form errors
2,5 to 4	43% to 60%	Pulse-controlled tightening with impact wrench.	Screwdriver set with tightening torque, as above.	Low values for: → Large number of setting attempts (tightening torque). → On horizontal axis of screwdriver curve. → Zero-backlash pulse transmission.	

8.3 Example of Procedure

Attention!

This procedure cannot replace calculations as defined in VDI 2230 (Association of German Engineers), and it does not correspond to the state-of-the-art. Nevertheless, it can at least prevent bolts breaking during assembly work with bolts for which no calculation has been made.

Step 1: Coefficient of friction μ_{over} corresponds to the friction class.

The lowest coefficient of friction practically achievable with the state of the surfaces and lubrication of the thread and contact area must be selected. For simplification, $\mu_{over} = 0.14$ is assumed for bolts that have not been given any after-treatment.

Step 2: Maximum assembly tightening torque M_A .

The maximum tightening torque is defined for each specific product below 90 percent utilization of the 0.2% permanent elongation limit ($R_{p0.2}$) or the apparent limit of elasticity (R_{el}). These values can be found in table 1.

Step 3: Tightening factor α_A :

This takes into account the variation of the tightening force achievable during assembly between F_M min and F_M max. The bolt is dimensioned for the maximum tightening torque so that it will not be overstressed during assembly. The imprecision of the tightening process is caused by:

- Errors calculating the coefficient of friction
- Variation of the frictional behaviour and repeating accuracy
- Differing tightening methods
- Device, operating and reading errors

The tightening factor α_A has to be selected in accordance with how the above-mentioned influences can be controlled. These values can be found in table 2.

Step 4: Assembly tightening torque M_A of the tool

This is the torque set on the tool, for example a mechanical screwdriver.

$$M_{AWerkzeug} = M_A \max. - \left(\frac{M_A \max. - M_A \min.}{2} \right)$$

$$M_A \min. = \frac{M_A \max.}{\alpha_A}$$

Example: Maximum tightening torque $M_A \max. = 425Nm$
 Tightening factor $\alpha_A = 1.7$

$$\rightarrow M_{AWerkzeug} = \frac{1}{2} \left(M_A \max. + \frac{M_A \max.}{\alpha_A} \right) = \frac{1}{2} \left(425Nm + \frac{425Nm}{1.7} \right)$$

$$\rightarrow M_{AWerkzeug} = 337,5Nm$$

Step 5: Check

Thoroughly check the bolted connections with a torque wrench.