

1 Foreword

1.1 General Instructions

This guide will help you to use the RUD System SWA safely, properly and profitably. When you follow the instructions in this guide, you will

- Increase the reliability and service life of the RUD System SWA and the plant
- Avoid dangers
- Reduce repairs and down times

This guide must

- **Be available at all times at the place of use**
- **Be read and followed by everyone who works on the RUD System SWA**

The RUD System SWA has been manufactured according to the state-of-the-art and in compliance with the recognized safety rules. However, improper handling or use for other than intended purpose may endanger the life and limb of the user or third parties and/or damage the elevator system or other tangible assets.

Spare parts must fulfil the technical requirements specified by RUD Ketten. This is guaranteed in the case of original spare parts, as they are subjected to continuous quality control by a quality management system certified under ISO 9001. Third party spare parts may, under certain circumstances, change the specified design characteristics of the system, and lead to serious defects which, in such a case, would not be the responsibility of RUD Ketten.

Use a suitably equipped workshop for performing maintenance work. Only the manufacturer can guarantee to carry out a professional overhaul or repair.

This guide has been drawn up with the greatest possible care. However, if you would like further information, please contact:

RUD Ketten
Rieger & Dietz GmbH u. Co. KG
Friedensinsel
73432 Aalen/Germany
Telephone +49 7361 504-0
Fax +49 7361 504-1523
rudketten@rud.com
www.rud.com

© 2007.

This guide is copyright protected. RUD Ketten reserves the right to make changes.



1.2 Intended Usage

- The RUD System SWA is a vertical elevator system for bulk materials.
- In stationary operation, the permitted power transfer through the components when conveying a specific material at a specific speed and with an appropriate distance between axes is specified in the order placed with RUD and in the confirmation of order by RUD. Any other use or use going beyond the intended use – for example higher conveying capacities or speeds, conveying other materials, or use under unapproved operating conditions – shall be regarded as use for other than the intended purpose.
- Usage for the intended purpose also includes complying with this fitting and operating guide, and complying with the inspection and maintenance specifications.

The manufacturer shall not be liable for damage resulting from usage for other than the intended purpose. The user shall bear the risk alone.

2 Safety Instructions

2.1 Explanation of Symbols and Notices

 <p>Warning!</p>	<p>Danger to life and limb, or substantial material damage can occur if the appropriate safety instructions are not followed.</p>
 <p>Attention!</p>	<p>Undesirable consequences or working conditions can arise if the appropriate safety instructions are not followed.</p>

2.2 General

 <p>Warning!</p>	<p>Follow the safety instructions. Otherwise there is danger to the life and limb of the user and third parties, and of damage to the machine and other tangible assets.</p>
---	---

- Mounting, dismounting, repairs, overhauls, and wear measurement may only be performed by competent persons who are familiar with the operating manuals and trained people.
- Inform the operating personnel and appoint supervisors before starting maintenance work.
- Secure machines and equipment against being started unintentionally.
- Switch off the main control systems, remove keys, and attach warning notices.
- Before mounting/dismounting work, secure the chain strand against movement. When mounting/dismounting chain equipment, a one-sided load can set the chain in motion and cause injuries which may prove to be fatal.
- Protect the working area against falling materials and components.
- When mounting and replacing individual parts or larger modules, attach and secure them carefully to the lifting equipment so that they cannot become a source of danger. Only use suitable and technically faultless lifting equipment and load hitching tackle.
- Do not stand or walk under suspended loads.
- As a rule, all components must be mounted and dismantled in an electrically dead state, unless otherwise stated. Risk of crushing!
- All parts of the plant must have cooled down to the extent that they can be touched without causing burns.

- Appoint only operating personnel with valid certificates of entitlement to hitch loads and instruct crane drivers. The spotter must remain in view of the operator or be in voice contact with him.
- The platforms provided and climbing aids complying with safety regulations must be used for assembly work above head height. Do not use machine parts as climbing aids. Wear protection against falling when performing maintenance work at great heights.
- Operating and process materials must be disposed of safely and in a way that does not harm the environment.
- As a matter of principle, no welding work is permitted to be done on round steel chains, chain couplings or case-hardened module components. The chain must not be used as a ground connection to the steel structure for electric welding.
- Welding, burning and grinding work may only be performed on the plant when this has been expressly authorized. Before starting welding, burning or grinding work, clean the plant and its surroundings of dust and combustible materials, and ensure adequate ventilation. There could, for example, be a risk of fire or explosion.
- Ensure that screw connections are tightened with the defined torque. Always check these connections with a torque wrench.
- Persons are not allowed to ride on the conveyor.
- For safety reasons, it is forbidden to make any modifications or alterations to the components without the manufacturer's authorization.
- All methods of working which are of questionable safety are forbidden.
- In addition to the operating instructions, comply with and implement the generally applicable, legal and other binding accident prevention and environmental protection regulations. For example, the handling of hazardous substances and the provision and wearing of personal protective clothing and equipment.

2.3 Care and Maintenance

- Wherever necessary, cordon off the maintenance area, allowing a wide safety margin.
- Before starting maintenance work, cordon off the working area of the machine/equipment to prevent the access of unauthorized persons. Attach or put up suitable notices advising of the maintenance work.
- Any material adhering to or remaining in the buckets can come loose and fall out. Switch off the material feed, and empty the bucket elevator before opening the inspection flaps. Wear a safety helmet while working.

3 Description

On positive discharge snubbed bucket elevators, the RUD System SWA has a toothed drive and non-toothed guide wheels. We also recommend this layout for central discharge bucket elevators, but they can be driven by plain chain wheels.

The RUD System SWA consists of the following parts:

- Sprocket wheel with replaceable individual teeth or chain wheel **20 or 40**
- Chain wheel **40**
- Space-saving RSP chain coupling or FL flat coupling **60**
- SWA bucket suspension **80**
- Bucket **110**
- Round steel chain **10**

The components are delivered packed separately.

Note!

Please comply with the following general operating instructions for this system:

- **Multipart RUD sprocket wheels** (F20533 / WV1)
- **Chain wheel** (F80522 / WV1)
- **Specified RUD chain couplings** (F20538 / WV1), (F20537 / WV1)
- **RUD conveyor chains** (F20521 / WV1)
- **Bucket attachment SWA** (F80526 / WV1)

4 Fitting

4.1 Mount the sprocket wheels and chain wheels on the appropriate shafts

1. Shrink on a pair of grooved wheels, both marked with the same colour, on a shaft.
2. Mount the wheels with a separation of distance "a" with 2 spacing screws (fig. 1). (There are corresponding boreholes in the wheels. The spacing screws are not supplied by RUD.)
3. Mount the sprocket wheels and chain wheels so that the centres of the wheels, are vertically aligned with one another.
4. Raise the guide wheel shaft at the start of the guide unit. That makes subsequent assembly easier.

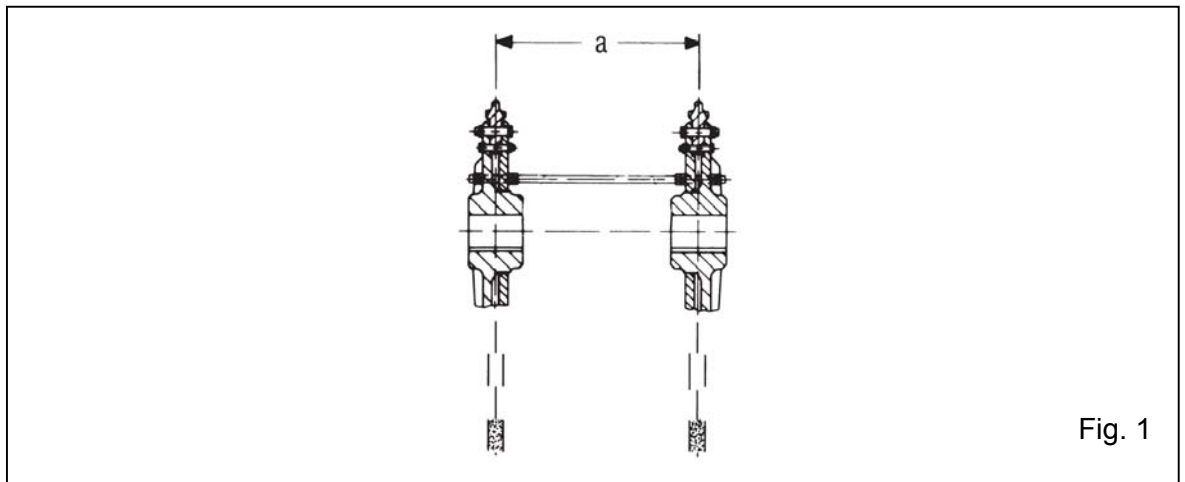

Fig. 1

4.2 Align the shafts

Align the shafts exactly parallel and horizontally. This and correct positioning of the wheel centres are absolutely essential.

4.3 Join the ends of the individual chain strands with chain couplings.

4.4 Pull the connected chain strands into the system (figs. 2 & 3).

Note!

The welds in the vertically arranged links must face the centre of the wheel when they pass over the sprocket wheels and chain wheels (figs. 2 & 3). Otherwise, bending and tensile stresses could lead to the welds breaking.

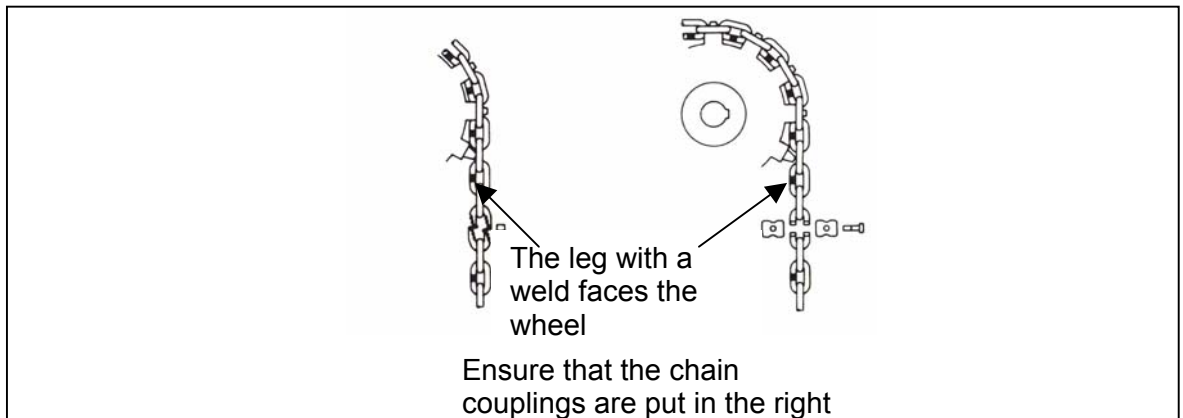

Fig. 2

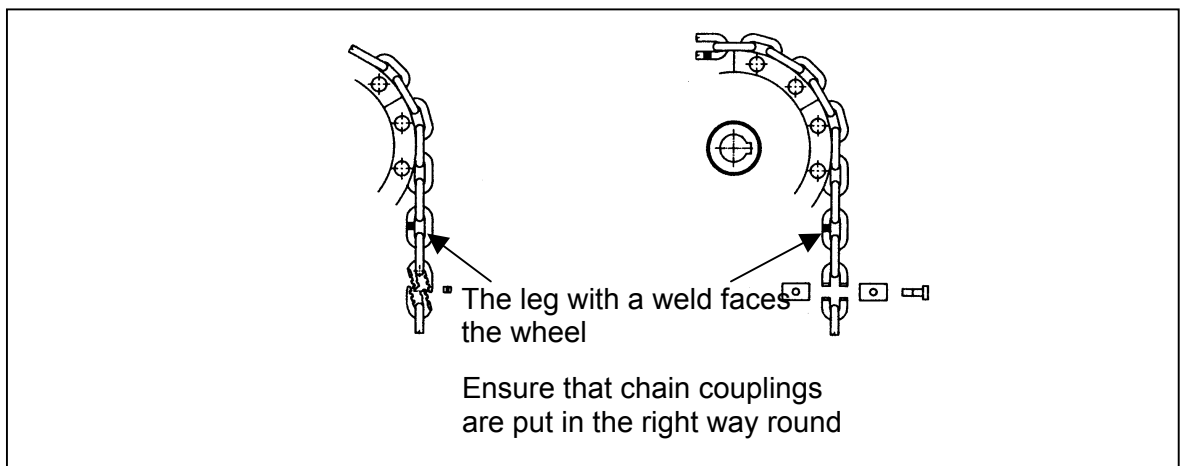

Fig. 3

Note!

When the chain couplings are fitted, the nuts of the bolted joints must face toward the center of the bucket elevator. This prevents damage occurring to the chain couplings and system.

Retighten all chain couplings before bringing the bucket elevator into operation. Check that all the nuts and bolts on the couplings are tightly seated once again when they are at operating temperature. Retighten if necessary.

Bolted connections in bolt strength class 8.8, locking nuts V according to DIN 980-8. The permissible bolt tightening torques are to be found in the table in the last section.

4.5 Join the ends of the chain loops (fig. 4).

Raise the guide wheel shaft at the start of the guide unit.
Carefully detach superfluous chain links (see Disassembly).
Join the ends of the chain loops with chain couplings.

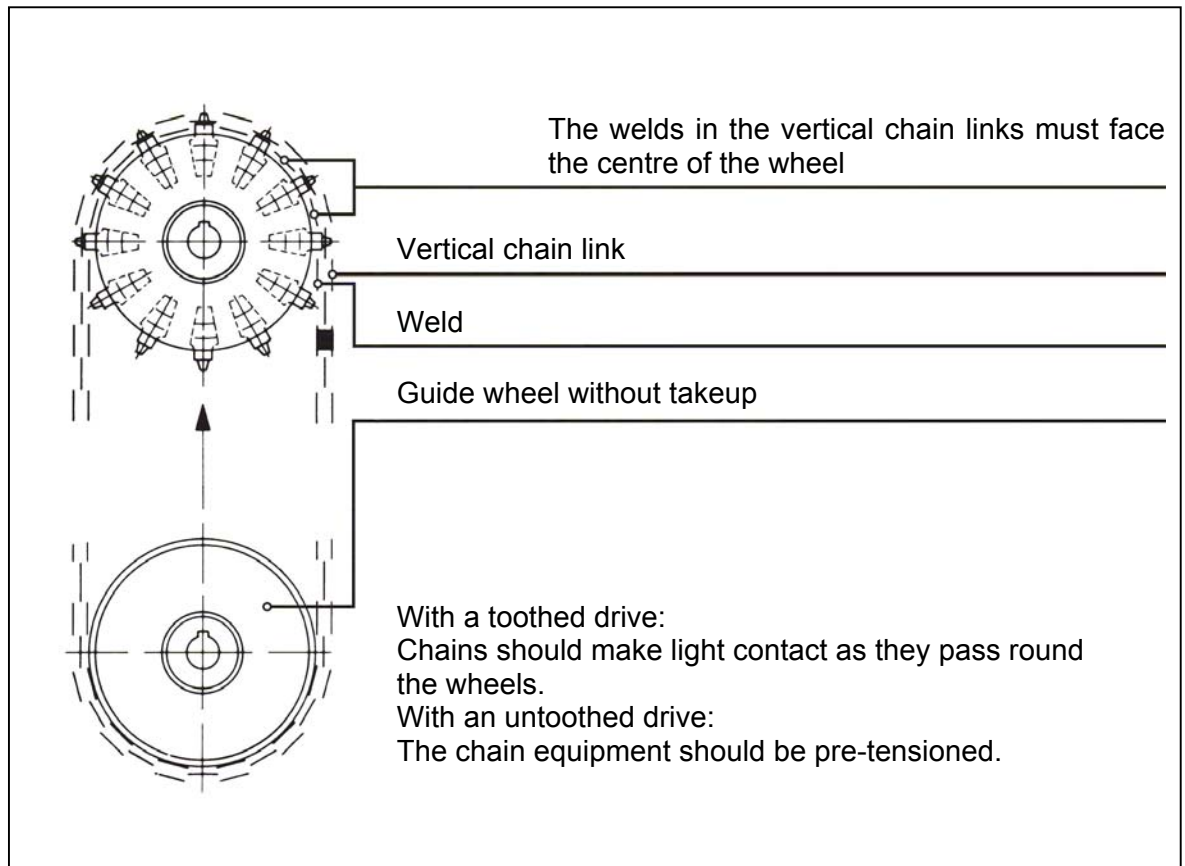



Fig. 4

4.6 Mount the SWA and the buckets

 <p>Warning!</p>	<p>Secure the chain strand against moving. A state of imbalance could cause movement.</p>
--	--

4.7 Setting the guide wheels for a toothed drive

The complete station is suspended on two spindles, which are permanently connected to the moveable bearings. The guide wheel shaft must have a range of adjustment of at least three chain link pitches.

When using our RUD drive sprocket wheels, the lower guide wheel can be run under normal operating conditions without additional gravity takeup tension.

This adjustable arrangement enables the distance between axles to be continually corrected for creep deformation of the round steel chain (running-in characteristics) and for the chain wear that occurs over long periods of operation.

Note!

For bucket elevators carrying material hotter than the ambient temperature, make the setting at the maximum temperature.

1. Set the guide wheels with the aid of the spindles.
2. The chain must lightly touch the guide wheels.
3. The sag between chain and guide wheel should be between 5 and 10 mm.

Correct setting:

- Wheels rotate when the system is running.
- Wheels are no longer lifted vertically.

The guide wheels must rotate during operation. This prevents excessive wear of the bearing races.

Note!

If the guide wheels become blocked: Vertical chain links dragging over the wheels can suffer superficial thermal shock cracks. These lead to fatigue fractures.

4.8 Setting the guide wheels for an untoothed drive

Takeup tension has to be applied to the chain when our chain wheels are used as drive wheels. This can be achieved with a spring tension or gravity takeup station. On principle, the chain tension should not be greater than that required to facilitate smooth, trouble-free operation.

Note!

Do not apply excessive takeup tension. This can substantially increase the wear on the chain.

1. The takeup tension required depends on the grain size and density of the material conveyed. Please follow the instructions of the bucket elevator manufacturer concerning takeup tension:
2. Check the chain tension regularly.
3. New chains must be checked more frequently.
4. Lengthening of the chain through wear can be compensated for by readjusting the guide wheel.

4.9 Loading the buckets

Note!

Comply with the following general guidelines.

1. Ensure that the buckets are loaded uniformly and centrally.
2. Do not load one side of the buckets. This leads to differing loads on the chain loops, and thus to one loop wearing faster than the other. This leads to the buckets assuming a tilted position.
3. If an angled feed is unavoidable, then structural measures are required. For example, discharge plates or concave feed chutes could be fitted to counteract the imbalance.

5 Disassembly

5.1 Shortening the chain

It is important to shorten the chain at the right time. Shorten the chain before it has lengthened so much that the panelling of the guide station or the floor of the bucket elevator are damaged.



Warning!

**Secure the chain strand against moving.
A state of imbalance could cause movement.**

Shorten the chain as follows:

1. All buckets must be completely empty, check for missing and damaged buckets.
2. Stop the elevator in a position advantageous for shortening the chains.
3. Switch off the elevator, and secure the chain strands against running off.
4. Raise the guide wheel shaft at the start of the guide unit.
5. The chains must be slack enough to open and remove the same number of links from both strands.
6. Attach and tighten the chain couplings.
7. Lower the guide wheel shaft and set it as described in section 4.5.
8. Remove the means holding the chain strands.
9. Reconnect the electrical supply to the motor, and make a trial run of the bucket elevator.

5.2 Exchanging individual teeth

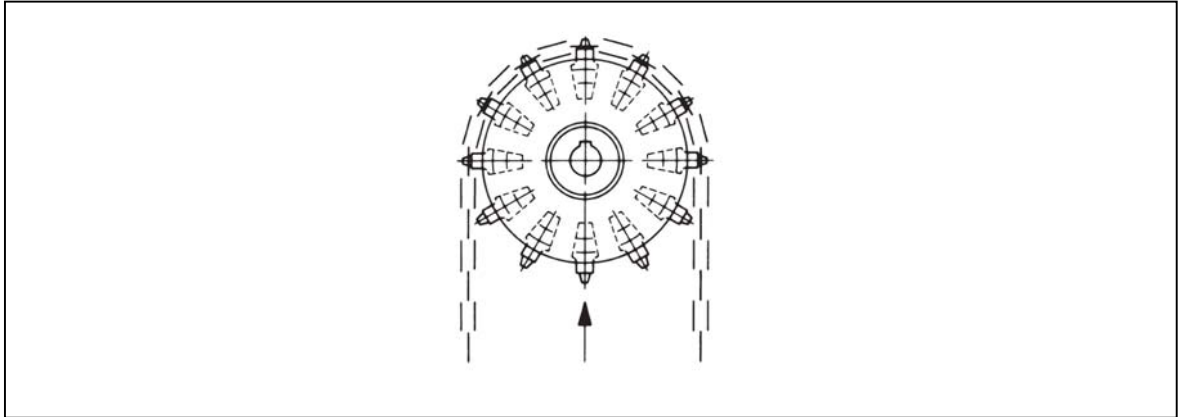

Fig. 5

For replacement parts: ↑ In this case, exchange individual teeth without removing the chain (fig. 5). When exchanging the chain (fitting replacement parts), also exchange the chain couplings and individual teeth at the same time.

Bolted connections in bolt strength class 8.8, locking nuts V according to DIN 980-8. The permissible bolt tightening torques are to be found in the table in the last section.

5.3 Exchanging sprocket wheel segments

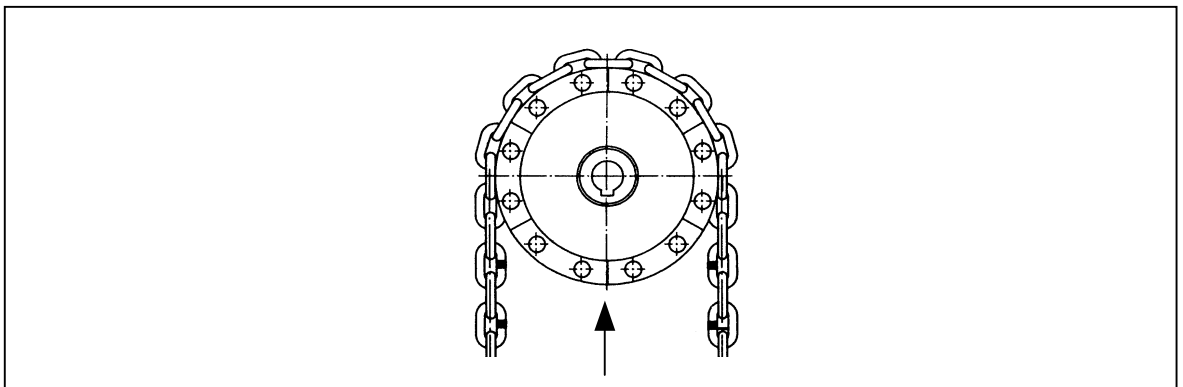

Fig. 6

For replacement parts: ↑ In this case, exchange segments without removing the chain (fig. 6). When exchanging the chain (fitting replacement parts), also exchange the chain couplings and segments at the same time.

Bolted connections in bolt strength class 8.8, locking nuts V according to DIN 980-8. The permissible bolt tightening torques are to be found in the table in the last section.

5.4 Dismantling the system



Warning!

**Dismount the buckets in such a way that the chain remains in balance.
Secure the chain strand against moving. A state of imbalance could cause movement.**

1. All bucket must be completely empty.
2. Switch off the elevator, and secure the chain strands against running off.
3. Dismount all buckets and bucket attachments from the elevator system.
4. Raise the guide wheel shaft at the start of the guide unit.
5. The chain must be slack enough to open.
6. Remove the means holding the chain strands.
7. Pull the chain out of the bucket elevator.
8. Remove the remaining chain couplings outside the bucket elevator.
9. Dismount the wheels from the shafts.

6 Care and Maintenance

We recommend that you keep records of your maintenance work on the bucket elevators, including their running times and the repairs that have been made. Only well-maintained bucket elevators achieve long running times.

6.1 Lubrication

Under normal circumstances, RUD conveyor chains do not require any lubrication. The chains may only be lubricated with standard engine oil. Grease must not be used. Dirty chains should be cleaned before being lubricated.

6.2 Takeup tension

Check the tension in the chains regularly, especially during the running-in phase of new chains and/or where the loop lengths are long. The takeup tension must not be greater than that required for the chain to run faultlessly under normal operating conditions. The takeup tension must be the same in all the chain loops.

The chain sag must be checked at regular intervals.
Readjust the guide wheels as and when necessary.

Note!

- **Excessive tension shortens the service life of the system.**
- **The chain sag must not be excessive. This causes additional inter-link movements during the scooping process. This, in turn, increases the wear on the chain.**

6.3 Monitoring

Examine chains, couplings, sprocket wheels, chain wheels and bucket attachments every six months, or at least annually, for damage, corrosion and points of unusual wear. At the same time, examine the buckets for deformation and cracked welds. Pay particular attention to the condition of the bolted joints and safety components. Rectify all defects found without delay.

7 Wear and Replacement State of Wear

Examine chains, couplings, sprocket wheels, guide wheels and flange-mounted parts every six months, or at least annually, for damage, corrosion and signs of unusual wear. At the same time, examine the buckets for deformation and cracked welds.

Note!

Components must always be replaced when damage occurs which directly or indirectly endangers the safety or operation of the system.

Evaluation of the wear measurements provides information about the maintenance work which needs to be done and when the elevator chains need to be changed.

If wear has lengthened the chain so that the vertical chain link touches the flank of the tooth behind it:

Fit individual teeth with an enlarged link support.

Exchange the individual teeth when the chain wear reaches 1.5-1.8%.

Exchange round link chains when the wear reaches about 3.5%.

When the elevator chains are exchanged, the individual teeth also have to be replaced at the same time.

7.1 Wear limits of RUD components

RUD round steel chains and chain couplings	Maximum chain wear of about 3.5% in relation to the nominal pitch of the chain.	
RUD individual teeth	Maximum wear on the chain link rest of the individual teeth of about 0.18 x d	
RUD chain wheel (also follow the instructions in F80522 / WV1)	RUD drive and guide wheels with exchangeable segments	
	Maximum wear	
	Dimension A [mm]	Width of groove B+ [mm]
	∅ 500	5.0
	∅ 630	6.0
	∅ 710	7.0
	∅ 800	9.0
	∅ 900	10.0
	∅ 1000	12.0
	∅ 1250	13.0
SWA	After the chain has been exchanged, the SWA may be able to be used again.	

(d = nominal diameter of chain)

8 Maximum Permissible Bolt Tightening Torques

The factors influencing the tightening torques stated in VDI 2230 must be taken into account when mounting bolted parts. Retighten all nuts after two weeks' operation, and ensure that they are tightly seated.

8.1 Table 1: Maximum Tightening Torques

Thread size	For bolt strength class 8.8 with overall coefficient of friction $\mu_{\text{over}} = 0.14$		For 2win and SWA threads with overall coeff. of friction $\mu_{\text{over}} = 0.14$		For DIN 555 hex nuts quality class 5	For DIN 934 hex nuts quality class 8	For DIN 980V hex nuts
	Tightening torque (Nm)	Tightening torque (ft-pd)	Tightening torque (Nm)	Tightening torque (ft-pd)	Tightening torque (Nm)	Tightening torque (Nm)	Tightening torque (Nm)
M 6	10	7					
M 8	25	18					
M 10	49	35			30	51	55
M 12	85	62			52	89	95
M 14	135	98			83	140	149
M 16	210	152	149	108	127	213	225
M 20	425	307	293	212	245	420	439
M 22	580	420					
M 24	730	528	506	366	420	725	752
M 27	1100	796					
M 30	1450	1049	1000	723	847	1451	1487
M 33	1900	1347					
M 36	2450	1772	1700	1230	1480	2531	2575

8.2 Table 2: Recommended Values for the Tightening Factor α_A :

Tightening factor α_A	Variation	Tightening method	Setting method	Comments	
1.7 to 2.5	26% to 43%	Torque-controlled tightening with mechanical screwdriver	The screwdriver is set with a tightening torque comprising a nominal tightening torque (for estimated coefficient of friction) plus an allowance.	Low values for: → Large number of checks (tightening torque) → Screwdriver with breaking coupling	Low values for: → Small angles of rotation, i.e. relatively rigid connections. → Relatively soft backing. → Backings which do not tend to scuff. Higher values for: → Large angles of rotation, i.e. relatively flexible connections. → Very hard backing coupled with rough surface. → Form errors
2,5 to 4	43% to 60%	Pulse-controlled tightening with impact wrench.	Screwdriver set with tightening torque, as above.	Low values for: → Large number of setting attempts (tightening torque). → On horizontal axis of screwdriver curve. → Zero-backlash pulse transmission.	

8.3 Example of Procedure

Attention!

This procedure cannot replace calculations as defined in VDI 2230 (Association of German Engineers), and it does not correspond to the state-of-the-art. Nevertheless, it can at least prevent bolts breaking during assembly work with bolts for which no calculation has been made.

Step 1: Coefficient of friction μ_{over} corresponds to the friction class.

The lowest coefficient of friction practically achievable with the state of the surfaces and lubrication of the thread and contact area must be selected. For simplification, $\mu_{\text{over}} = 0.14$ is assumed for bolts that have not been given any after-treatment.

Step 2: Maximum assembly tightening torque M_A .

The maximum tightening torque is defined for each specific product below 90 percent utilization of the 0.2% permanent elongation limit ($R_{p0.2}$) or the apparent limit of elasticity (R_{el}). These values can be found in table 1.

Step 3: Tightening factor α_A :

This takes into account the variation of the tightening force achievable during assembly between $F_M \text{ min}$ and $F_M \text{ max}$. The bolt is dimensioned for the maximum tightening torque so that it will not be overstressed during assembly. The imprecision of the tightening process is caused by:

- Errors calculating the coefficient of friction
- Variation of the frictional behaviour and repeating accuracy
- Differing tightening methods
- Device, operating and reading errors

The tightening factor α_A has to be selected in accordance with how the above-mentioned influences can be controlled. These values can be found in table 2.

Step 4: Assembly tightening torque M_A of the tool

This is the torque set on the tool, for example a mechanical screwdriver.

$$M_{A\text{Werkzeug}} = M_A \text{ max.} - \left(\frac{M_A \text{ max.} - M_A \text{ min.}}{2} \right)$$

$$M_A \text{ min.} = \frac{M_A \text{ max.}}{\alpha_A}$$

Example: Maximum tightening torque $M_A \text{ max.} = 425\text{Nm}$
 Tightening factor $\alpha_A = 1.7$

$$\rightarrow M_{A\text{Werkzeug}} = \frac{1}{2} \left(M_A \text{ max.} + \frac{M_A \text{ max.}}{\alpha_A} \right) = \frac{1}{2} \left(425\text{Nm} + \frac{425\text{Nm}}{1.7} \right)$$

$$\rightarrow M_{A\text{Werkzeug}} = 337,5\text{Nm}$$

Step 5: Check

Thoroughly check the bolted connections with a torque wrench.